

MAIN SPECIFICATIONS

Model		4FD150	4FD180	4FD200	4FD230	4FD240
Engine Model		HINO J08E-UM	HINO J08E-UM	HINO J08E-UM	HINO J08E-UM	HINO J08E-TM
Load Capacity	kg	15,000	18,000	20,000	23,000	24,000
Load Center	mm	900	900	900	900	1,250
Overall Width	A mm	2,935	2,960	3,040	3,045	3,045
Turning Radius (Outside)	B mm	4,950	4,950	5,000	5,200	5,900
Overhead Guard Height (Cabin Height)	C mm	3,400	3,430	3,465	3,465	3,560
Length to Fork Face	D mm	5,265	5,290	5,370	5,545	6,315

ENGINE SPECIFICATIONS

Engine Model		HINO J08E-UM	HINO J08E-TM
Model		4FD150-4FD230	4FD240
Piston Displacement	CC	7,684	7,684
Rated Horsepower/r.p.m	kW	128 / 2,300	159 / 2,300
	JIS ps	174 / 2,300	216 / 2,300
Rated Torque/r.p.m	Nm	640 / 1,600	750 / 1,600
	JIS kgfm	65 / 1,600	76.5 / 1,600

J08E-UM, TM: Non-road Mobile Machinery (97/68/EC; Stage III A)
EPA Non-road Diesel Engine (40 CFR Part 89, Tier 3)

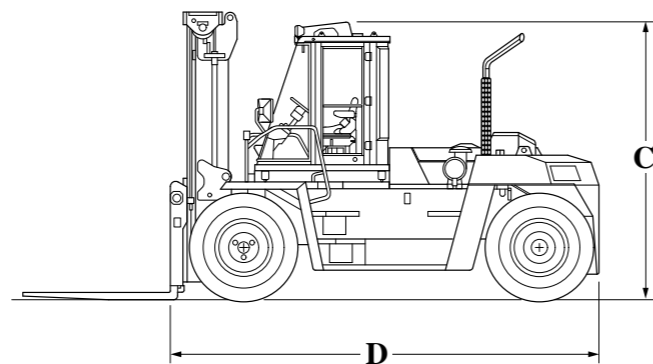
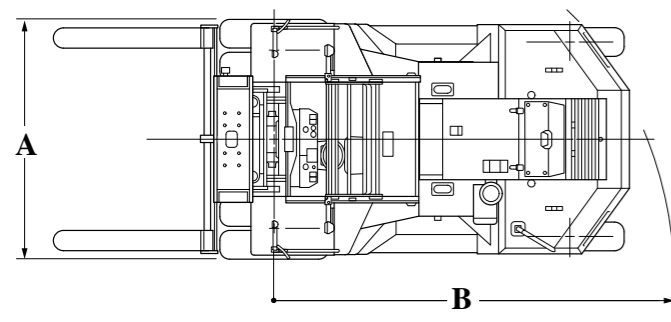

The data in this brochure is determined based on our standard testing condition.
The performance may vary depending on the actual specification and condition of the vehicle as well as the condition of the operating area.
Availability and specifications depend on market and are subject to change without notice.
Due to photography and printing, color of actual vehicle may vary from this brochure. Some photos have been computer-enhanced.
Please consult your Toyota representative for details.



Website



YouTube

All rights reserved by Toyota Industries Corporation.

15.0 to 24.0 ton SERIES



TOYOTA MATERIAL HANDLING INTERNATIONAL



Ecology and Economy, with Ease & Comfort.



Toyota offers a new large-capacity forklift based on these three types of ECO. Along with power and maneuverability, this forklift embodies and highlights all the many other features that heavy work demands. Toyota's new large-capacity forklift is ready to move. The right choice to meet your needs today.

Ecology LEAVES

Common-rail direct injection

Powerful

Low Emission AdVanced Engine Series

Toyota engine technology provides high power while also ensuring optimal fuel efficiency and low harmful gas emissions. The newly adopted cooling exhaust gas recirculation (EGR) system and intercooler dramatically lower NOx and CO2 emissions and contribute to better fuel consumption.

Rated Horsepower/r.p.m Rated Torque/r.p.m
 4FD150 **128kW** **640Nm**
 4FD230 /2,300 /1,600

Rated Horsepower/r.p.m Rated Torque/r.p.m
 4FD240 **159kW** **750Nm**
 /2,300 /1,600

NOx Emissions
38% Reduction*

CO2 Emissions
10% Reduction*

*Compared to HINO J08E-T Engine



Ease & Comfort

A low-vibration, low-noise, fully floating pillar-less cabin with excellent field of vision and large capacity air conditioner ensure that work is performed in a comfortable environment. Furthermore, superb features such as the power assisted control lever, smooth two-stator torque converter, and electrical switch parking brake, full hydraulic power steering with steering synchronizer help to eliminate stress and reduce operator fatigue.



Multi-function Suspension Seat

The seat with reclining function, seatbelt, and body weight adjustment is equipped as standard to provide operator comfort while working. A swivel seat is available as an option.



Easy cabin entry and exit*



Comfortable operation when traveling in reverse*
 *with optional swivel seat

Full Hydraulic Power Steering with Steering Synchronizer

Knob displacement has been eliminated by using the knob positioning control to automatically align the rear wheel cornering angle and steering.

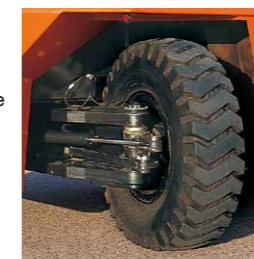

Key-off Lift Lock

The lift is automatically locked when the engine key is turned off.

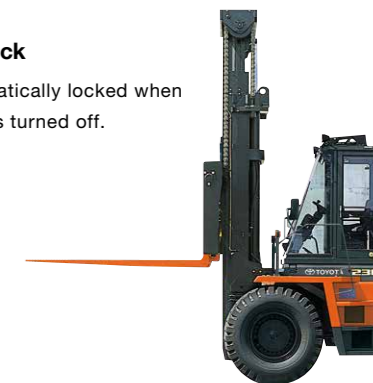

Economy

With efficiency and cost in mind, this new large capacity forklift is equipped with a wide range of features designed for efficient maintenance. Hydraulic cylinders allow the cabin to be tilted open 45° for doing maintenance below the floor.



Wet Disc Brake with Dedicated Cooling Circuit

A dedicated oil cooler is used to perform forced cooling to prevent overheating. This highly reliable brake not only provides the operator with peace of mind, but also contributes to greatly reduced brake maintenance costs.

Wet Disc Brake

