

# Autopilot reach truck 1.6 - 2.5 ton



## **BT reflex** *AUTOPILOT*

RAE160

RAE250

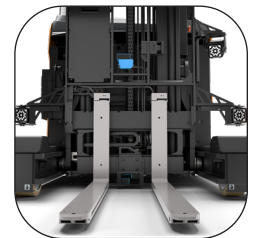

# Autopilot reach truck

Truck specifications					RAE160	RAE250
Identification	1.1	Manufacturer			Toyota	Toyota
	1.2	Model			RAE160	RAE250
	1.3	Drive			Electric	Electric
	1.4	Operator type			Seated/Automatic	Seated/Automatic
	1.5	Load capacity/rated load	Q	kg	1600	2500/2300 <sup>1)</sup>
	1.6	Load centre	c	mm	650	600/650 <sup>1)</sup>
	1.8	Load distance, centre of support arm wheel to face of forks	x	mm	See mast dimensions table	
	1.9	Wheelbase	y	mm	1395	1575
	Weight	2.1	Service weight including battery		kg	3927
2.3		Axle load, mast retracted without load, drive/support arm wheel		kg	2616/1313	3180/1649
2.4		Axle load, mast extended with load, drive/support arm wheel		kg	793/4734	729/6601
2.5		Axle load, mast retracted with load, drive/support arm wheel		kg	2101/3426	2630/4700
Wheels		3.1	Drive/support arm wheel			Vulkollan®/Vulkollan®
	3.2	Wheel size, front		mm	Ø 343x140	Ø 360x160
	3.3	Wheel size, rear		mm	Ø 300x106	Ø 350x106
	3.5	Wheels, number front/rear (x=driven wheels)			1x / 2	1x / 2
	3.7	Track width, rear <sup>2)</sup>	b <sub>11</sub>	mm	1134/1334	1134/1334
Dimensions	4.1	Tilt of fork, forward/backward (up/down)	α/β	deg	4°/-2°	4°/-2°
	4.2	Height, mast lowered	h <sub>1</sub>	mm	See mast dimensions table	
	4.3	Free lift	h <sub>2</sub>	mm	See mast dimensions table	
		Lift height	h <sub>23</sub>	mm	See mast dimensions table	
	4.5	Height, mast extended	h <sub>4</sub>	mm	See mast dimensions table	
		Height with navigation scanner	h <sub>20</sub>	mm	2605/2955/3405	2667/3017/3467
		Height eye navigation scanner	h <sub>21</sub>	mm	2586/2936/3386	2648/2998/3448
	4.7	Height of overhead guard (cab)	h <sub>6</sub>	mm	2426	2488
	4.10	Height support arms	h <sub>8</sub>	mm	329	363
	4.15	Height of lowered forks	h <sub>13</sub>	mm	55	60
	4.19	Overall length	l <sub>1</sub>	mm	2649	2755
	4.20	Length to face of forks	l <sub>2</sub>	mm	1399	1505
	4.21	Overall width <sup>2)</sup>	b <sub>1</sub>	mm	1270/1470	1270/1470
	4.22	Overall width over support arms (including scanners) <sup>2)</sup>	b <sub>2</sub>	mm	1570/1770	1570/1770
	4.23	Fork dimensions	s/e/l	mm	40/100/1250 <sup>3)</sup>	45/125/1250 <sup>3)</sup>
	4.24	Fork carriage ISO 2328, class/type A, B			2A	2A
	4.25	Fork carriage width	b <sub>3</sub>	mm	843	843
	4.26	Width over forks <sup>4)</sup>	b <sub>5</sub>	mm	252/392/516/622/698	277/417/541/647
	4.27	Distance between support arms	b <sub>4</sub>	mm	900/1100	900/1100
	4.28	Reach distance	l <sub>4</sub>	mm	509	609
4.31	Ground clearance, with load, below mast	m <sub>1</sub>	mm	38	38	
4.32	Ground clearance, centre of wheelbase	m <sub>2</sub>	mm	38	38	
4.37	Length across support arms	l <sub>7</sub>	mm	1877	2091	
Performance data	5.1	Travel speed, with/without load, automatic mode, drive wheel direction		m/s	2,5/2,5	2,5/2,5
	5.1	Travel speed, with/without load, automatic mode, fork direction		m/s	1,9/1,9	1,9/1,9
	5.2	Lift speed, with/without load		m/s	0,36/0,68	0,37/0,64
	5.3	Lowering speed, with/without load		m/s	0,55/0,59	0,53/0,58
	5.4	Reach speed, with/without load		m/s	0,20/0,28	0,20/0,28
	5.8	Max. gradeability, with/without load		%	8/8	7/7
	5.10	Service brake			Electric	Electric
Electric motor	6.1	Drive motor rating S2 60 min		kW	9,0	10,5
	6.2	Lift motor rating S3 15%		kW	11,0	15,0
	6.4	Battery voltage, nominal capacity K <sub>s</sub>		V/Ah	48/420	48/420
	6.5	Battery weight		kg	875-1030	1055-1235
	6.6	Energy consumption acc. to VDI cycle <sup>5)</sup>		kWh/h	3,7	5,2
	Other	8.1	Type of drive control			Variable AC
8.4		Sound level at driver's ear according to EN 12 053		dB(A)	64	62
		Safety of laser products			Class 1 (EC 60825-1)	
		Height from floor to centre of auto-charging plate		mm	693	686
		Longitudinal distance from reference point to centre of auto-charging plate		mm	916	1089

n) Note, new value/text in this version of data sheet.

1) Load centre 650mm in auto mode

2) Distance between supportarms 900/1100 mm.

3) Other alternative are available.

4) For the load camera usable width over fork distance at fork length 1250 mm.

5) Based on RRE-H2 Contact your supplier for more information.

All data are based on table configuration. Other configurations may give other values.

Truck performance and dimensions are nominal and subject to tolerances.

Toyota Material Handling Manufacturing Sweden AB products and specifications are subject to change without notice.

# Mast dependent dimensions

Dimensions				RAE160	RAE250	
Mast type				Triplex Hi-Lo - B	Triplex Hi-Lo - C <sup>1)</sup>	Triplex Hi-Lo - D
	Battery compartment		mm	347	419	419
1.8	Load distance, centre of support arm wheel to face of forks	x	mm	307	390	334
4.20	Length to face of forks	$l_2$	mm	1399	1505	1561
4.28	Reach distance	$l_4$	mm	509	609	554
4.35	Turning radius Rotate on point.	$W_a$	mm	1715	1903	1903

1) Max lift height 9000mm

# Mast dimensions

				RAE160						RAE250							
				Triplex Hi-Lo - B						Triplex Hi-Lo - C				Triplex Hi-Lo - D			
	Lift height	$h_{23}$	mm	4850	5700	7000	8000	9000	10000	4850	5700	7000	8000	9000	10000	11000	12000
4.4	Lift	$h_3$	mm	4795	5645	6945	7945	8945	9945	4795	5645	6945	7945	8945	9945	10945	11945
4.2	Height, mast lowered	$h_1$	mm	2249	2532	2966	3299	3632	3966	2247	2530	2936	3297	3630	3963	4297	4630
4.3	Free lift	$h_2$	mm	1741	2025	2459	2791	3125	3459	1733	2017	2449	2783	3117	3449	3783	4117
4.5	Height, mast extended	$h_4$	mm	6026	6876	8176	9176	10176	11176	6026	6876	8176	9176	10176	11176	11546	12546

# Aisle width Auto mode

		$A_{st}$ Rotate on point, PPS Muted					
		Load length	mm	800	1000	1200	
		Load width	mm	1200	1200	800	1000
Model	Mast type	Battery comp.					
<b>RAE160</b>	Triplex Hi-Lo - B	347	mm	2744	2890	2959	3002
<b>RAE250</b>	Triplex Hi-Lo - C	419	mm	2879	3015	3071	3118
	Triplex Hi-Lo - D	419	mm	2914	3057	3123	3167

# Lift capacities RAE160 - RAE250

Actual Capacity (kg)

Model	RAE160						RAE250					
	900		1100		900		1100					
Distance between support arms $b_4$ (mm)	900		1100		900		1100					
Battery compartment (mm)	347		347		419		419					
Load center LCP (mm)	Mast type	650 850	Mast type	650 850	Mast type	650 850	Mast type	650 850				
Lift height $h_{23}$ (mm)												
4850	B	1600 1260	B	1600 1280	C	2190 1680	C	2230 1710				
5700	B	1520 1180	B	1540 1200	C	2030 1560	C	2060 1590				
7000	B	1380 1080	B	1410 1100	C	1770 1390	C	1770 1420				
8000	B	1290 1010	B	1310 1030	C	1460 1150	C	1460 1150				
9000	B	1180 930	B	1200 950	C	1210 920	C	1210 920				
10000	B	1070 840	B	1090 860	D	1510 1260	D	1590 1290				
11000					D	1150 880	D	1300 990				
12000					D	800 610	D	1100 840				

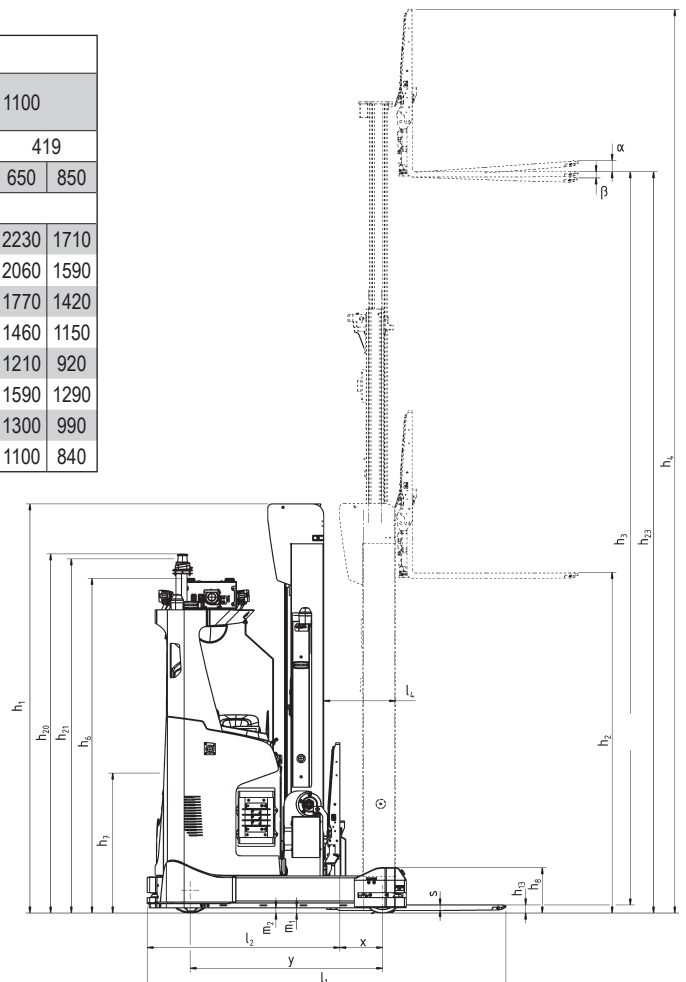
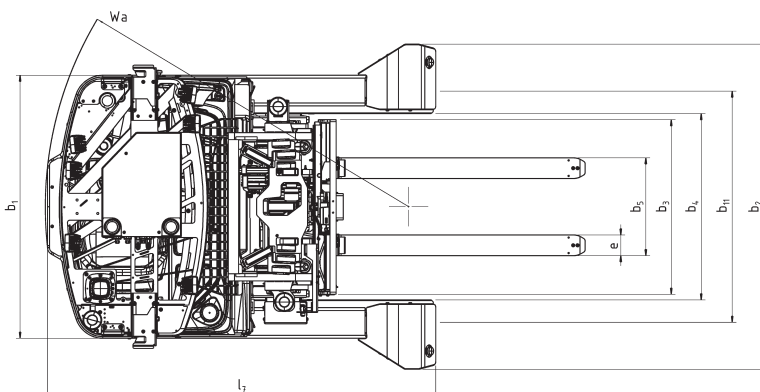

---

## Truck features:

- Automatic
  - loading and unloading
  - horizontal transport
  - vertical stacking
  - horizontal deep stacking
  - RS150 handling
- Maintenance handling
- Laser precision navigation
- Personal safety protection drive direction
- Personal safety protection fork direction
- Personal safety protection on sides
- Load presence and push detection
- Information display
- Auto charging Lithium-Ion battery
- Obstacle detection system forward (optional)
- Obstacle detection system sides (optional)
- Barcode scanner (optional)
- Blue/Red LED warning light fork/drive direction (optional)
- Advanced vision aided load handling (optional)
- Multi-load detection (optional)

